

Log Piston Pump Data

11.6 BHP Continuous Duty (13.8 BHP Intermittent Duty)

Log

Standard Cast ISO Drawing

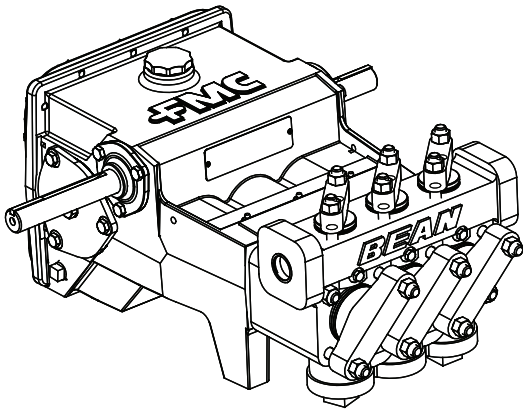

Specifications

Pump Model	Log
Configuration	Horizontal Triplex Piston
Number of Pistons	3
Stroke Length	2.25 Inches
Frame Load Rating	2,800 lbs
Pump Weight (Average)	200 lbs
Direction of Rotation	Top of shaft away from head
Internal Gear Ratio	3.6:1
Intermittent Duty Speed Rating	890 RPM
Continuous Duty Speed Rating	750 RPM
Ball Valve Max Speed Rating	625 RPM
Minimum Speed	360 RPM
Mechanical Efficiency	85%
Lubrication System (Standard)	Splash, Gravity Return
Lube Oil Capacity	2.25 Quarts
Lube Oil Type	SAE 30
Maximum Fluid Temperature	140 °F (250 °F Capability)
Minimum Fluid Temperature	0 °F (-20 °F Capability)
Standard Suction Size	1.50 Inch NPT
Standard Discharge Size	1.00 Inch NPT
Fluid End Material	Cast Iron
Valve Types	Disc Valves, Ball Valves
Hydraulic Motor Mount	SAE B - 4 Bolt with 1.25"-14T SAE C - 4 Bolt with 1.25"-14T

Performance Table

Pump Model	Piston Diameter (in)	Displacement (GAL/REV)	Maximum Pressure (PSI)	Pump Capacity (GPM) @ Input Speed (RPM)				
				350 RPM	625 RPM	700 RPM	750 RPM	890 RPM
Log13	1.625	0.0168	1,200	5.9	10.5	11.8	12.6	15.0
Log14	1.750	0.0195	1,000	6.8	12.2	13.7	14.6	17.4
Log18	2.250	0.0323	700	11.3	20.2	22.6	24.2	28.7

* Horsepower based on 85 or 90% mechanical efficiency. Actual application horsepower requirements can be calculated using the equation: $BHP = (GPM * PSI) / (1714 * 0.85 \text{ or } 0.90)$

* Pump capacities shown are based on 100% volumetric efficiency.

* Dimensions shown are for general sizing purposes and should not be used for construction. Contact FMC for actual dimensions of pump ordered.

* FMC reserves the right to modify this information without prior notice.

Log
 Cast Pump Engineering Dimensional Outline

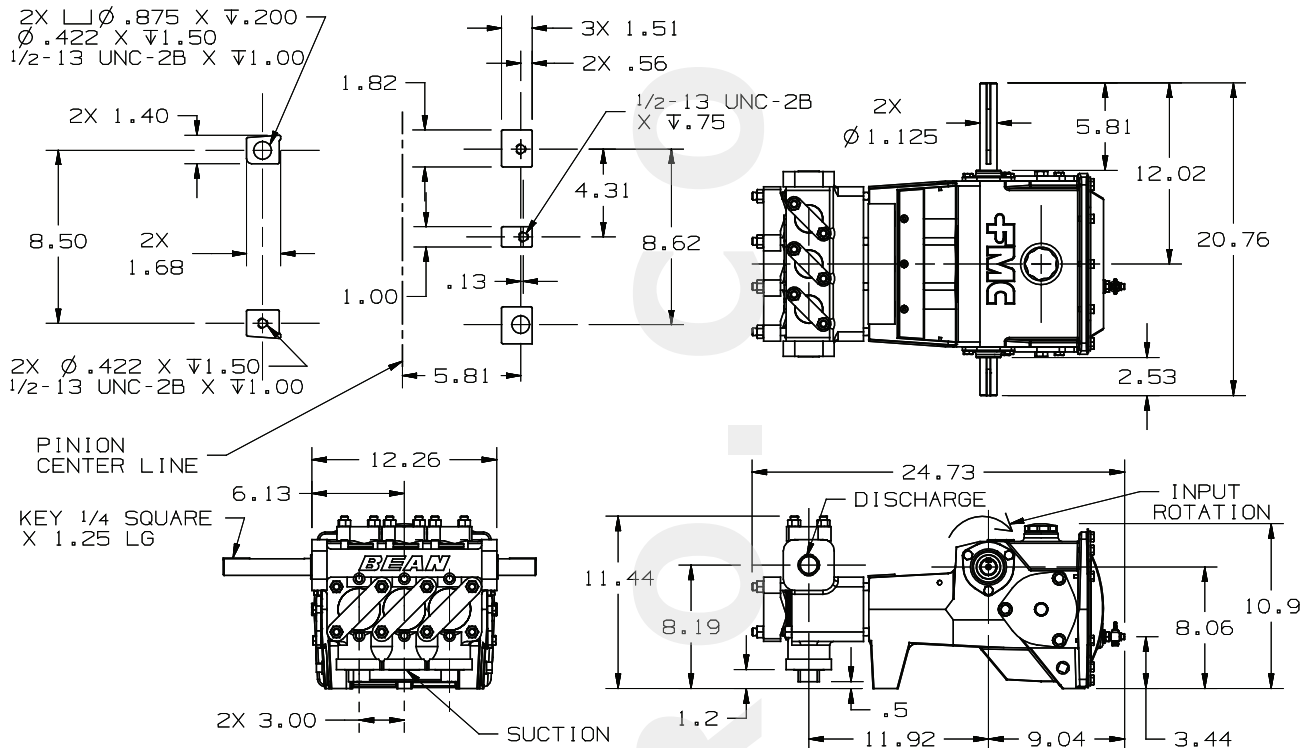

Log NPSHr value for Standard Disc Valves

Log NPSHr value for Standard Ball Valves

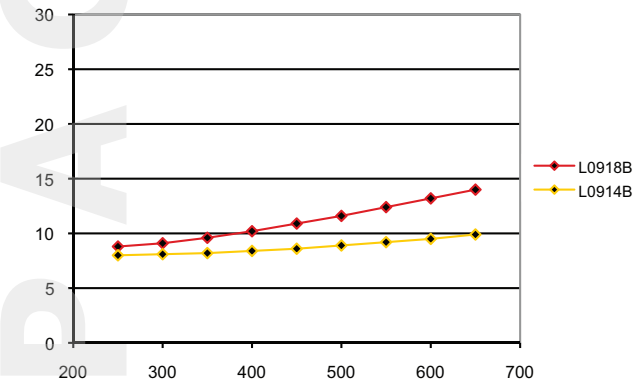
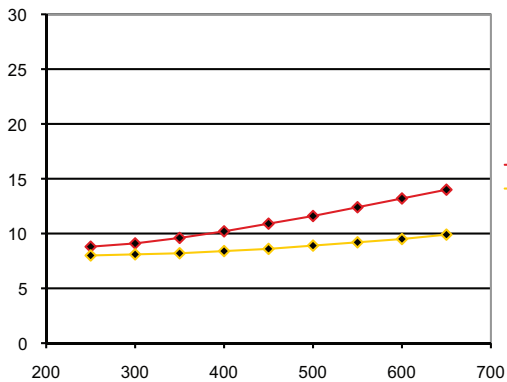

- FMC recommends NPSHa (available) exceeds NPSHr (required) by 5 feet of water.
- Take special consideration when calculating NPSHa. Recalculate NPSHa after pump model has been selected for more accurate values.
- NPSHr values are in feet of water. If you are pumping a different liquid than water, convert the required NPSH from water to the liquid being pumped by dividing the published NPSHr value by the specific gravity of the liquid being pumped.
- FMC published NPSHr values are based on test data collected on specific pumps at the factory and are estimated values. Actual NPSHr values for an ordered pump can only be determined by a factor test. For NPSH critical applications, contact the factory for additional information and request an NPSHr test performed on your pump before shipment.
- Pump drawing dimensions in inches.