

LogHV Piston Pump Data (High Volume)

22.6 BHP Continuous Duty (27.1 BHP Intermittent Duty)

Log HV

Standard Cast ISO Drawing

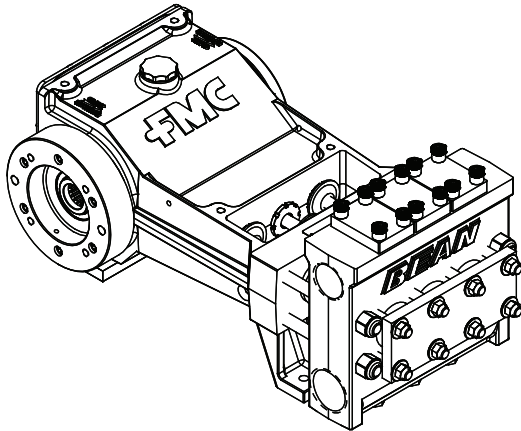

Specifications

Pump Model	Log-HV
Configuration	Horizontal Triplex Piston
Number of Pistons	3
Stroke Length	2.25 Inches
Frame Load Rating	3,200 lbs
Pump Weight (Average)	325 lbs
Direction of Rotation	Top of shaft toward head
Internal Gear Ratio	NA
Intermittent Duty Speed Rating	450 RPM
Continuous Duty Speed Rating	375 RPM
Ball Valve Max Speed Rating	NA
Minimum Speed	100 RPM
Mechanical Efficiency	90%
Lubrication System (Standard)	Splash, Gravity Return
Lube Oil Capacity	2.25 Quarts
Lube Oil Type	SAE 30
Maximum Fluid Temperature	140 °F (250 °F Capability)
Minimum Fluid Temperature	0 °F (-20 °F Capability)
Standard Suction Size	HD - 2.00 Inch NPT HV - 2.50 Inch NPT
Standard Discharge Size	HD - 1.50 Inch NPT HV - 2.00 Inch NPT
Fluid End Material	Ductile Iron, Nicle Aluminum Bronze
Valve Types	Disc Valves, Abrasion Resistant (AR) Valves
Hydraulic Motor Mount	SAE B - 4 Bolt with 1.25"-14T SAE C - 4 Bolt with 1.25"-14T

Performance Table

Pump Model	Piston Diameter (in)	Displacement (GAL/REV)	Maximum Pressure (PSI)	Pump Capacity (GPM) @ Input Speed (RPM)				
				100 RPM	200 RPM	300 RPM	375 RPM	450 RPM
Log13-HV	1.625	0.0606	1,500	6.1	12.1	18.2	22.7	27.3
Log14-HV	1.750	0.0703	1,300	7.0	14.1	21.1	26.4	31.6
Log18-HV	2.250	0.1162	800	11.6	23.2	34.9	43.6	52.3

* Horsepower based on 85 or 90% mechanical efficiency. Actual application horsepower requirements can be calculated using the equation: $BHP = (GPM * PSI) / (1714 * 0.85 \text{ or } 0.90)$

* Pump capacities shown are based on 100% volumetric efficiency.

* Dimensions shown are for general sizing purposes and should not be used for construction. Contact FMC for actual dimensions of pump ordered.

* FMC reserves the right to modify this information without prior notice.

Log HV

Cast Pump Engineering Dimensional Outline

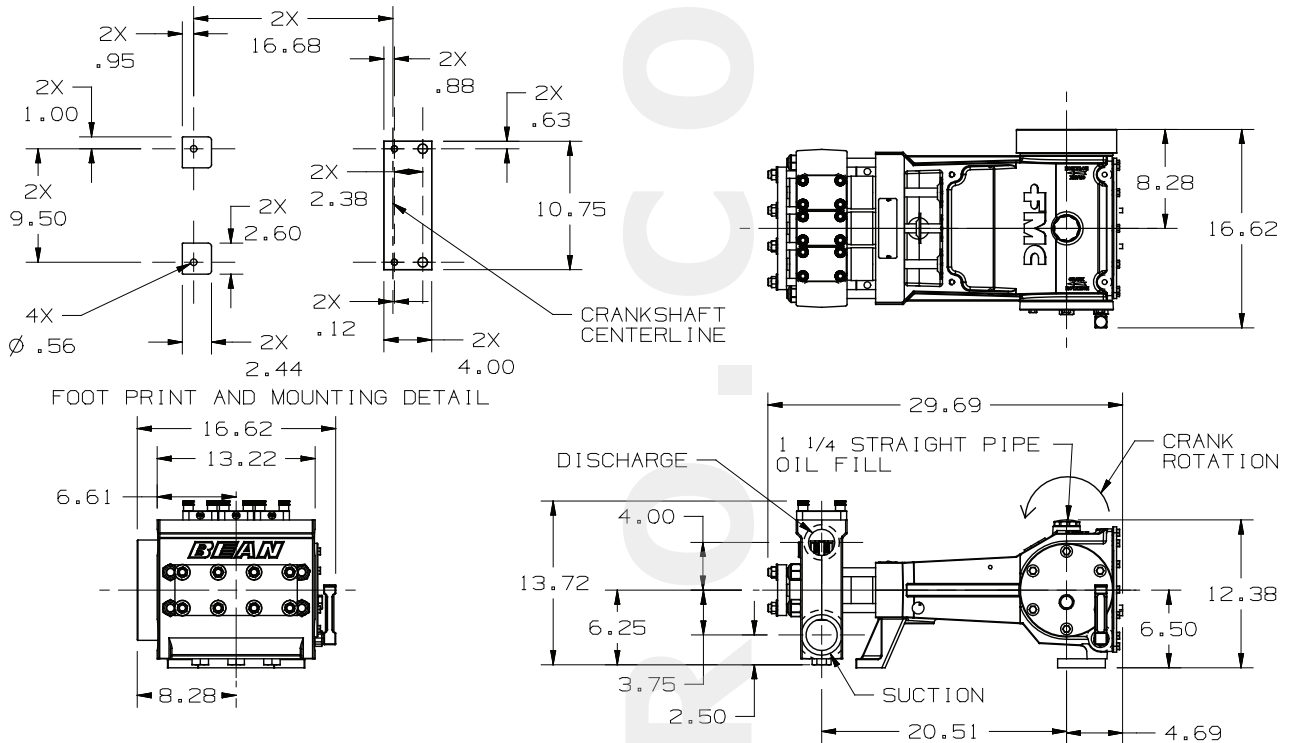

- FMC recommends NPSHa (available) exceeds NPSHr (required) by 5 feet of water.
- Take special consideration when calculating NPSHa. Recalculate NPSHa after pump model has been selected for more accurate values.
- NPSHr values are in feet of water. If you are pumping a different liquid than water, convert the required NPSH from water to the liquid being pumped by dividing the published NPSHr value by the specific gravity of the liquid being pumped.
- FMC published NPSHr values are based on test data collected on specific pumps at the factory and are estimated values. Actual NPSHr values for an ordered pump can only be determined by a factor test. For NPSH critical applications, contact the factory for additional information and request an NPSHr test performed on your pump before shipment.
- Pump drawing dimensions in inches.